

# Assembly Instructions For Traditional Style Single Action Grips

If you have any problems installing your Hogue grip, please call us at (805) 239-1440. We will be glad to help make sure your grip fits perfectly.

## HOGUE®

HOGUE® INC.  
P.O. BOX 91360  
HENDERSON, NV 89009  
1-800-438-4747  
Hogueinc.com

**IMPORTANT CONSUMER AND  
WARRANTY INFORMATION ON  
BACK OF PACKAGE**

CFID\_INS\_SA\_05142015

## A FEW WORDS ABOUT FIT

Unfortunately, due to large dimensional variances in certain single action revolver grip frames, your grips are supplied oversized and it is necessary to individually hand fit this grip.

Fitting can be accomplished one of four ways:

- 1) Do the work yourself following the directions entirely.
- 2) Have a gunsmith perform the work.
- 3) You can mail your grips to our shop for this purpose by completing steps 1-6 before sending the grips. We will perform the service of finishing the grips for a fee of \$35.00 plus postage and return them to you. Send your HOGUE MANUFACTURED GRIPS and payment to:  
**HOGUE GRIPS**  
550 Linne Road  
Paso Robles, CA 93446
- 4) As a last resort, Hogue Grips will custom fit and finish your grips to your gun. You can legally ship your revolver to our FFL licensed facility for this purpose. There is an additional fee (determined on a grip-by-grip basis) plus postage and insurance for this service. Please state the value of your gun when sending and insure for its full value. Send UPS only, along with payments to the above address.

blending it to the rest of the grip smoothly. You may need to frequently check the grips on the firearm during this process to achieve a flush fit on all straps. Do not work the wood while the grips are on the firearm. It is easy to permanently scratch the firearm's metal finish that way!

8. Sand the last small amount of wood to 220 grit or finer or Pearlite and Micarta to 600 grit or finer. Then they can be finished using a buffing compound and a hard sewn high speed powered buffing wheel. A Dremel tool can even do the job. Hard carnauba wax can be buffed onto the wood with a soft wheel to give an extra shine. This is how it is done at Hogue Grips but there are many other firearm stock finishes available by your local firearm shop. Pearlite grips will definitely need to be power buffed for a high gloss.

Good luck! If you require further assistance, call Hogue Grips at (805) 239-1440.

## FITTING INSTRUCTIONS

If you are equipped and wish to perform this yourself, the following detailed instructions will help. Read them entirely before starting to work.

1. Start by **MAKING SURE THE FIREARM IS UNLOADED** then remove the original grips.
2. Two things need to be done: Drill grip pin holes and finish the grip panels to the frame straps.
3. To properly locate the pin holes, remove the grip from the frame. Carefully lay one grip panel onto the frame, rotating it squarely into the "locating notch" making sure there is extra wood overlapping on all frame straps. You can locate the hole on the wood by drilling through the hole in the frame or marking through the hole by some other means. Only start the hole this way; it is likely the grip panel will not fit tight if the entire depth is drilled through the frame. Repeat for the other side grip panel.
4. Reinstall the grip pin, centering it in the frame.
5. Next, finish drilling the hole depth with the grip away from the firearm. If you keep checking the fit on the firearm as you drill deeper, you can get a snug pin-to-notch fit. Ideally, the hole will be best slightly off-center

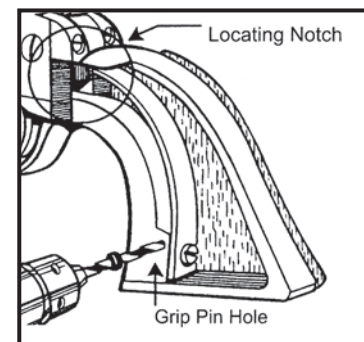

toward the bottom of the grip. Keep working until the hole is deep enough for the grip to lay completely flat. The hole size should be slightly larger than the pin. If it is a too tight press-fit, your grips could chip when removing them from the gun. This is especially important on brittle materials such as Pearlite. Repeat for other side grip panel.

6. Put both grip panels on the firearm making sure they lay completely flat. Using a very sharp lead pencil or other scribe, mark the frame straps onto the inside of the grip panels. If you decide to send your grips back for finishing, mark the grips with both

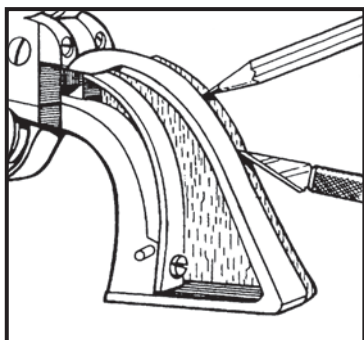

pencil and a sharp scribe. The point of a sharp knife works well. Be careful not to scratch the firearm when doing this. Remember, the better the line, the better the fit will be!

7. Remove the grips and carefully work the wood down to the scribed lines using files, belt sander, drum sander, etc. Shape the wood away from the edge

### IMPORTANT!

Check ALL functions of your firearm after grips are installed. Test fire your firearm.

## CARE AND MAINTENANCE

With proper care your new Hogue grip will provide you with many years of service. Although the hardwoods used are some of the hardest available (much harder than common walnut) they are still subject to the elements. **Avoid prolonged contact with moisture or oils.**

It is recommended that you remove your hardwood grips before cleaning your firearm. The finish used on your grip is a natural buffed carnauba wax (checkering has a clear lacquer finish.)

Care for your grip like any piece of hand rubbed furniture. With handling, your grip will take on a satin finish that can be maintained by buffing with a soft cloth. Or, like most, simply buff them a few times on your jeans. You may also use a furniture polish if you wish.

All of us at Hogue wish you many years of happy shooting with your new grip.

Hogue® is a registered trademark of Hogue, Inc.